



NGATTACHMENTS-NUR GROUP

TECHNICAL COMPOSITION

MACHINE MODEL	NG BUCKET 16-18 TON
SERIES	NG 16-18 T SERIES BUCKET
SPECIFICATION	HEAVY DUTY



MATERIAL COMPOSITION

No	Description	Material	Thickness (mm)	Explanation
1	BOSS X	Ç 1040	20	
2	HINGE PLATE	S355 J2	25	
3	HINGE BOTTOM BOX	S355 J2	15	
4	HINGE CENTER PLATE	S355 J2	15	
5	HINGE BOTTOM	S355 J2	20	
6	BOSS Y	Ç 1040	45	
7	VERTICAL EDGE	S355 J2	25	
8	LOWER VERTICAL EDGE	HARDOX 450	35	
9	SIDE WALL L-R	S355 J2	10	
10	BODY BOTTOM	S355 J2	10	
11	EDGE	HARDOX 450	35	
12	SIDE PROTECTION	HARDOX 450	10	
13	WEAR STRIPS	HARDOX 450	10	
14	REINFORCEMENT	S355 J2	10	
15	REINFORCEMENT	S355 J2	10	
16	TOOTH			
17	ADAPTER			
18	LOCK	OPTIONAL TYPE		
19	REINFORCEMENT	S355 J2	10	

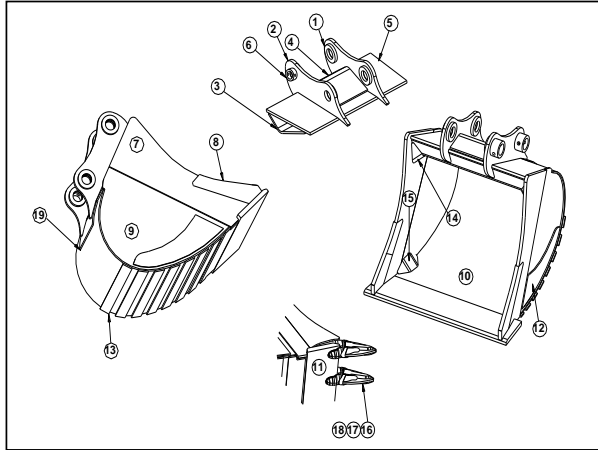

Model Specification

	NG 16-18 T L:1000	NG 16-18 T L:1100
Edge Length (mm)	1000	1100
Capacity SAE (m³)	0,90	0,95
Weight (kg)	710	775
Teeth	4	4

WITHOUT ADAPTOR & TOOTH & SEGMENTS

WWW.NGATTACHMENTS.COM +90(312)440 60 34 E-MAIL:EXPORT@NURGROUP.COM.TR