



NG ATTACHMENTS-NUR GROUP

MACHINE MODEL	NG BUCKET 70-80 T SERIES
SERIES	NG 70-80 T BUCKET
SPECIFICATION	HEAVY DUTY



MATERIAL COMPOSITION				
No	Description	Material	Thickness (mm)	Explanation
1	HINGE PLATE	S355J2	50	ARCELOR
2	HINGE SIDE RL-LH	S355J2	30	ARCELOR
3	HINGE BOTTOM	S355J2	30	ARCELOR
4	HINGE CENTER PLATE	S355J2	30	ARCELOR
5	VERTICAL EDGE	HARDOX 450	60	SSAB
6	SIDE PLATE	HARDOX 450	20	SSAB
7	L.SIDE PROTECTION	HARDOX 450	50	SSAB
8	BODY	HARDOX 450	20	SSAB
9	EDGE	HARDOX 450	50	SSAB
10	WEAR STRIPS	HARDOX 450	20	SSAB
11	WEAR STRIPS	HARDOX 450	20	SSAB
12	WEAR STRIPS	HARDOX 450	20	SSAB
13	WEAR STRIPS	HARDOX 450	10	SSAB
14	ADAPTOR	OPTIONAL TYPE		
15	TEETH			
16	LOCK			

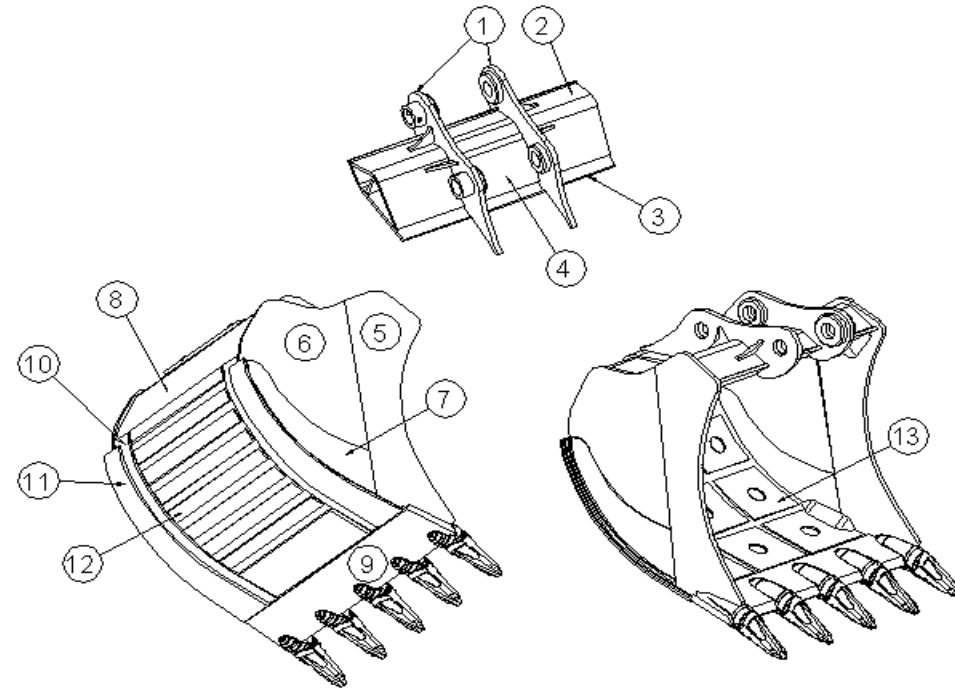

Model Specification

NG 70-80 T L:2300

Edge Length (mm)	2300
Capacity SAE (m ³)	5,85
Weight (kg)	4840
Nr Teeth	6

WWW.NGATTACHMENTS.COM TELEPHONE:+90(312)440 60 34 E-MAIL:EXPORT@NURGROUP.COM.TR