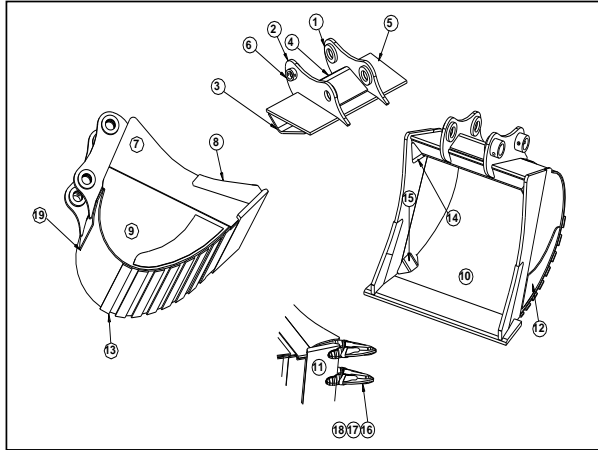

**BUCKET SPECIFICATION**

MACHINE MODEL	NG BUCKET 7-10 T
SERIES	NG 10 T SERIES
SPECIFICATION	HEAVY DUTY

NGATTACHMENTS-NUR GROUP

MATERIAL COMPOSITION				
No	Description	Material	Thickness (mm)	Explanation
1	BOSS-X	Ç 1040	11	
2	HINGE PLATE	S355 J2	18	ARCELOR
3	HINGE BOTTOM BOX	S355 J2	10	ARCELOR
4	HINGE CENTER PLATE	S355 J2	10	ARCELOR
5	HINGE BOTTOM	S355 J2	10	ARCELOR
6	BOSS Y	Ç 1040	50	
7	VERTICAL EDGE	S355 J2	20	ARCELOR
8	LOWER VERTICAL EDGE	HARDOX 450	30	SSAB
9	SIDE WALL L-R	S355 J2	12	SSAB
10	BODY BOTTOM	S355 J2	10	SSAB
11	EDGE	HARDOX 450	30	SSAB
12	SIDE PROTECTION	HARDOX 450	6	SSAB
13	WEAR STRIPS	HARDOX 400	10	SSAB
14	REINFORCEMENT	S355 J2	10	ARCELOR
15	REINFORCEMENT	S355 J2	10	ARCELOR
16	TOOTH			
17	ADAPTER			
18	LOCK	OPTIONAL TYPE		
19	REINFORCEMENT	ST52-3	10	

**Model Specification**

	NG-7-10 T L:650 MM	NG 7-10 T L:800 MM
Edge Length (mm)	650	800
Capacity SAE (m ³)	0,35	0,46
Weight (kg)	315	360
Teeth	3	4

WITHOUT ADAPTOR & TOOTH & SEGMENTS

WWW.NGATTACHMENTS.COM +90(312)440 60 34 E-Mail:export@nurgroup.com.tr