



NG ATTACHMENTS-NUR GROUP

BUCKET SPECIFICATION

MACHINE MODEL	NG BUCKET 30-35 T
SERIES	NG 36 T SERIES
SPECIFICATION	HEAVY DUTY



MATERIAL COMPOSITION

No	Description	Material	Thickness (mm)	Explanation
1	HINGE PLATE	S355JR2	30	
2	HINGE SIDE RL-LH	S355JR2	18	
3	HINGE BOTTOM	S355JR2	18	
4	HINGE CENTER PLATE	S355JR2	18	
5	VERTICAL EDGE	HARDOX 450	40	
6	SIDE PLATE	S355JR2	15	
7	L.SIDE PROTECTION	HARDOX 450	30	
8	BODY	S355JR2	15	
9	EDGE	HARDOX 450	50	
10	WEAR STRIPS	HARDOX 450	12	
11	WEAR STRIPS	HARDOX 450	12	
12	WEAR STRIPS	HARDOX 450	12	
13	WEAR STRIPS	HARDOX 450	10	
14	ADAPTOR	OPTIONAL TYPE		
15	TEETH			
16	LOCK			

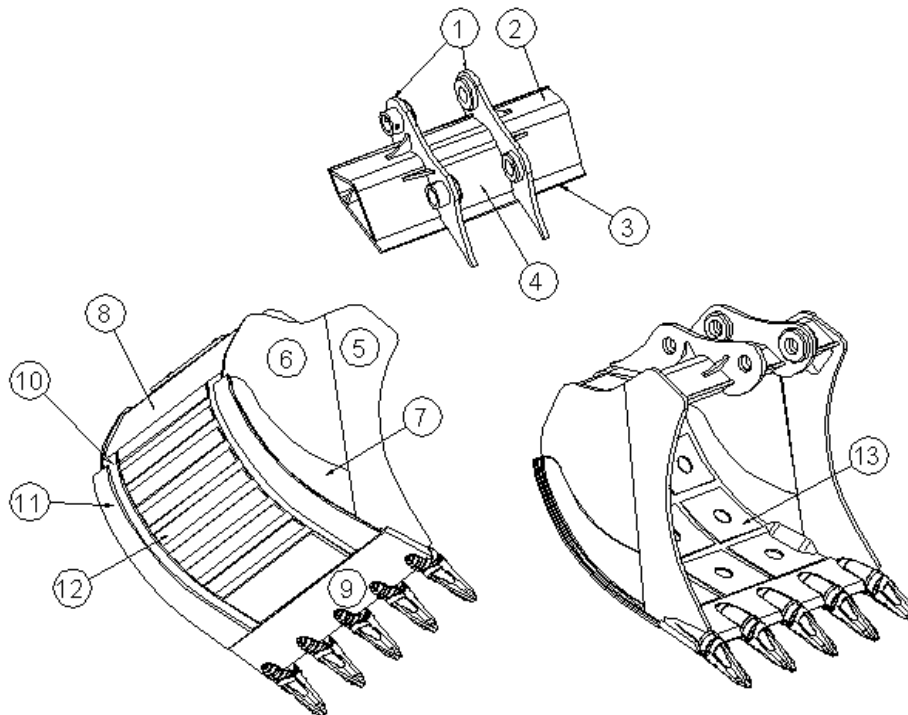

Model Specification

	NG 30-35 T L:1600	NG 30-35 T L:1550	NG 30-35 T L:1200	NG 30-35 T L:800	NG 30-35 T L:700
Edge Length (mm)	1600	1550	1200	800	700
Capacity SAE (m ³)	2,1	1,9	1,6	1,0	0,8
Weight (kg)	1550	1450	1280	1055	985
Nr Teeth	5	5	4	3	3