



NGATTACHMENTS-NUR GROUP

BUCKET SPECIFICATION

MACHINE MODEL	NG BUCKET 24-27 T
SERIES	NG 27 T SERIES
SPECIFICATION	HEAVY DUTY



MATERIAL COMPOSITION

No	Description	Material	Thickness (mm)	Explanation
1	HINGE PLATE	S355 JR2	25	ARCELOR
2	HINGE SIDE RL-LH	S355 JR2	18	ARCELOR
3	HINGE BOTTOM	S355 JR2	18	ARCELOR
4	HINGE CENTER PLATE	S355 JR2	18	ARCELOR
5	VERTICAL EDGE	HARDOX 450	35	SSAB
6	SIDE PLATE	S355 JR2	12	ARCELOR
7	L.SIDE PROTECTION	HARDOX 450	25	SSAB
8	BODY	S355 JR2	10	ARCELOR
9	EDGE	S355 JR2	40	ARCELOR
10	WEAR STRIPS	HARDOX 450	10	SSAB
11	WEAR STRIPS	HARDOX 450	12	SSAB
12	WEAR STRIPS	HARDOX 450	12	SSAB
13	WEAR STRIPS	HARDOX 450	10	SSAB
14	ADAPTOR	OPTIONAL TYPE		
15	TEETH			
16	LOCK			

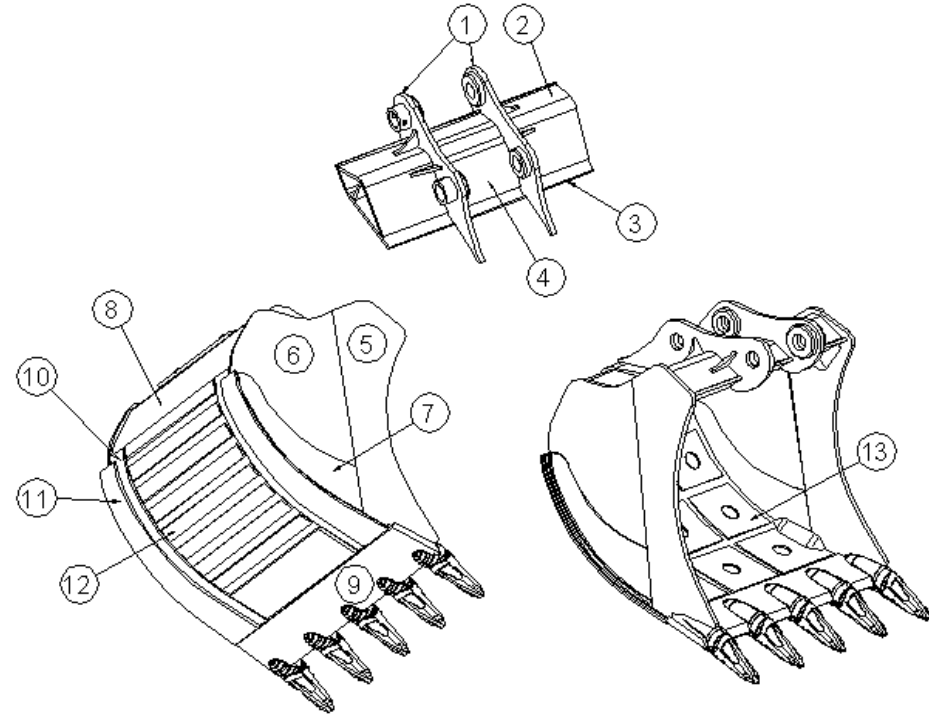

Model Specification

	NG-24-27 T L:1500	NG-24-27 T L:1400	NG-24-27 T L:1200	NG-24-27 T L:1000	NG 24-27 T L:800
Edge Length (mm)	1500	1400	1200	1000	800
Capacity SAE (m ³)	1,55	1,45	1,24	1,0	0,82
Weight (kg)	1290	1205	1035	865	675
Nr Teeth	5	5	4	4	3