

MACHINE MODEL	NG 100-125 T SERIES
SERIES	NG 100-125 T BUCKET
SPECIFICATION	EXTRA HEAVY DUTY

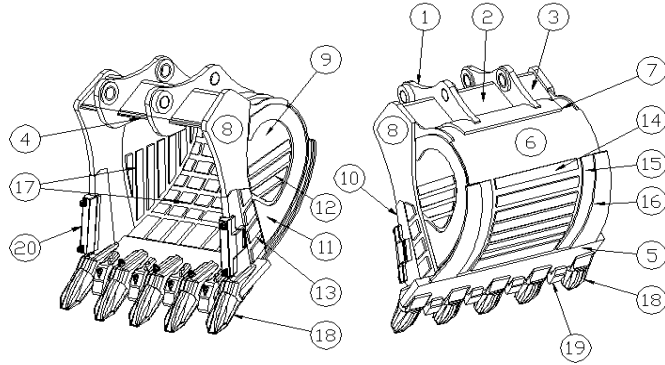

MATERIAL COMPOSITION				
No	Description	Material	Thickness (mm)	Explanation
1	HINGE PLATE R-L	S355 JR2	70	ARCELOR
2	CENTER BOX	S355 JR2	40	ARCELOR
3	SIDE BOX R-L	S355 JR2	40	ARCELOR
4	H.BOTTOM PLATE	S355 JR2	40	ARCELOR
5	EDGE	S355 JR2	90	ARCELOR
6	BODY	S355 JR2	25	ARCELOR
7	REINFORCEMENT	HARDOX 450	40	SSAB
8	U.VERTICAL EDGE	S355 JR2	70	ARCELOR
9	SIDE WALL	HARDOX 450	25	SSAB
10	L.VERTICAL EDGE	HARDOX 450	80	SSAB
11	SIDE PROTECTION	HARDOX 450	25	SSAB
12	WEAR STRIPS	HARDOX 450	20	SSAB
13	WEAR STRIPS	HARDOX 450	25	SSAB
14	WEAR STRIPS	HARDOX 450	30	SSAB
15	WEAR STRIPS	HARDOX 450	25	SSAB
16	WEAR STRIPS	HARDOX 450	25	SSAB
17	WEAR STRIPS	HARDOX 450	20	SSAB
18	ADAPTOR+TEETH+LOCK			
19	SEGMENTS			
20	SEGMENTS			
		MTG-ESCO		

**Model Specification**

NG 100-125 T L:2400

Edge Length (mm)	2400
Capacity SAE (m <sup>3</sup> )	6,75
Weight (kg)	8385
Teeth	6

**PRICES ( € )**

WITHOUT ADAPTOR &amp; TOOTH &amp; SEGMENTS