

MACHINE MODEL	NG 160-180 T SERIES
SERIES	NG 160-180 T BUCKET
SPECIFICATION	EXTRA HEAVY DUTY

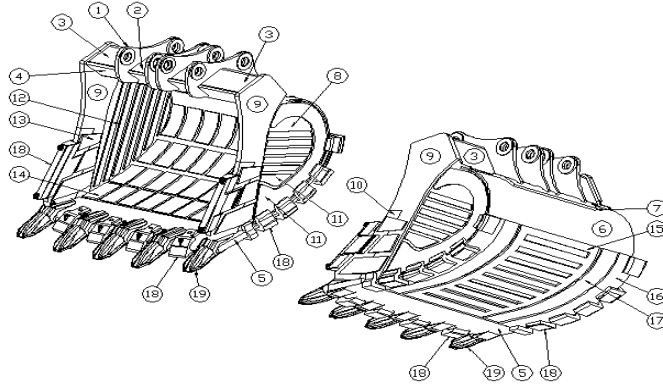

MATERIAL COMPOSITION				
No	Description	Material	Thickness (mm)	Explanation
1	HINGE PLATE R-L	S355 JR2	45	ARCELOR
2	CENTER BOX	S355 JR2	40	ARCELOR
3	SIDE BOX R-L	S355 JR2	40	ARCELOR
4	H.BOTTOM PLATE	S355 JR2	40	ARCELOR
5	EDGE	S355 JR2	100	ARCELOR
6	BODY	S355 JR2	25	ARCELOR
7	REINFORCEMENT	HARDOX 450	40	SSAB
8	SIDE WALL	S355 JR2	25	ARCELOR
9	U.VERTICAL EDGE	HARDOX 450	70	SSAB
10	L.VERTICAL EDGE	HARDOX 450	80	SSAB
11	SIDE PROTECTION	HARDOX 450	25	SSAB
12	WEAR STRIPS	HARDOX 450	20	SSAB
13	WEAR STRIPS	HARDOX 450	20	SSAB
14	WEAR STRIPS	HARDOX 450	20	SSAB
15	WEAR STRIPS	HARDOX 450	30	SSAB
16	WEAR STRIPS	HARDOX 450	25	SSAB
17	WEAR STRIPS	HARDOX 450	25	SSAB
18	SEGMENTS			
19	ADAPTOR+TEETH+LOCK		MTG-ESCO	

Model Specification

	NG 160-180 L:2800	NG 160-180 L:3100
Edge Length (mm)	2800	3100
Capacity SAE (m ³)	11,25	12,35
Weight (kg)	12150	13450
Teeth	5	5

WITHOUT ADAPTOR & TOOTH & SEGMENTS