

BUCKET SPECIFICATION

NG ATTACHMENTS-NUR GROUP BUCKET DATA SHEET	
MACHINE MODEL	NG BUCKETS 50-65 TONS
SERIES	NG 50-65 SERIES
SPECIFICATION	HEAVY DUTY

MATERIAL COMPOSITION				
No	Description	Material	Thickness (mm)	Explanation
1	HINGE PLATE	ST52-3	40	ARCELOR
2	HINGE SIDE RL-LH	ST52-3	30	ARCELOR
3	HINGE BOTTOM	ST52-3	30	ARCELOR
4	HINGE CENTER PLATE	ST52-3	30	ARCELOR
5	VERTICAL EDGE	HARDOX 450	40-45	SSAB
6	SIDE PLATE	HARDOX 450	15	SSAB
7	L.SIDE PROTECTION	HARDOX 450	40	SSAB
8	BODY	HARDOX 450	15	SSAB
9	EDGE	HARDOX 450	70	SSAB
10	WEAR STRIPS	HARDOX 450	15	SSAB
11	WEAR STRIPS	HARDOX 450	20	SSAB
12	WEAR STRIPS	HARDOX 450	20	SSAB
13	WEAR STRIPS	HARDOX 450	10	SSAB
14	ADAPTOR	ROCK TYPE		
15	TEETH			
16	LOCK			

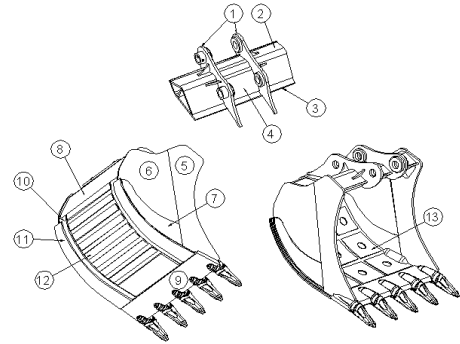

Model Specification

Edge Length (mm)	1800
Capacity SAE (m³)	4
Weight (kg)	3230
Nr Teeth	6

WWW.NGATTACHMENTS.COM